

CAPACITY	SYMBOL/ SERIAL NO.	CIRCUIT DIAGRAM
AC 230V, 50Hz		
18W x 2		

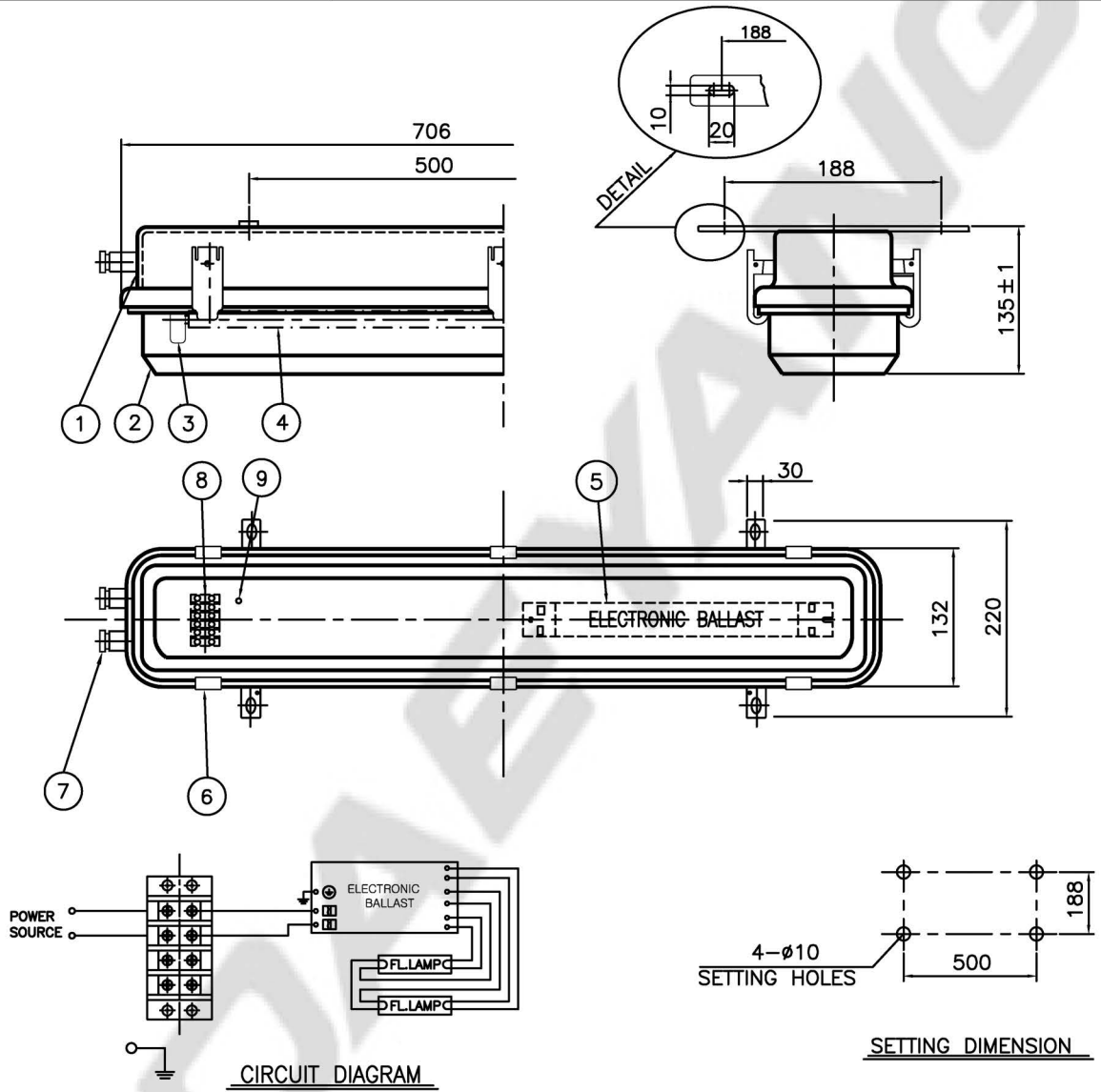

9	INSIDE EARTH BOLT	STAINLESS STEEL 304	1		5	ELECTRONIC BALLAST	-	2	
8	TERMINAL BLOCK	PHENOL	1	4P	4	LAMP	-	2	
7	CABLE GLAND	BRASS	2	ø14~ø17.5	3	LAMP HOLDER	POLYCARBONATE	4	
6	LATCH	STAINLESS STEEL 316L	6		2	GLOBE	POLYCARBONATE	1	
5					1	BODY	STAINLESS STEEL 316L	1	
NO	NAME OF PARTS	MATERIAL	Q'TY	REMARKS	NO	NAME OF PARTS	MATERIAL	Q'TY	REMARKS

APPROVED	B. K. KIM	UNIT	MM	TITLE; FLUORESCENT CEILING LIGHT (SURFACE TYPE) FOR MARINE USE	
CHECKED		SCALE	N/S		
DRAWING	B. I. KIM	COLOR	N-9.3		
DATE	2015.12.04	IP	67		
		MODEL NO.	FL220WS-0235EIUWNM2w17h12	WEIGHT	6.4 Kg
		DWG NO.	L11450882	SHEET NO.	